

A large, flowing, wavy graphic in shades of green and yellow, resembling a wave or a ribbon, positioned horizontally across the middle of the page.

# greenWave<sup>®</sup>

Because Böhler Welding Cares



*Otto Schuster*

Otto Schuster,  
Senior Vice President SBU Equipment

When talking about sustainability, these days it is often about economic or social sustainability, which is particularly demanded in big companies by customers, the capital market and other stakeholders.

The origin of sustainability, however, lay in ecological sustainability, i.e. the careful use of resources – of all kinds – in a way that enables future generations to live an equally mindful and carefree life.

“Welding”, for example, is an area that brings both positive and negative factors to sustainability. While the use of steel products is said to have a particular longevity and high-tech steel in the automotive sector or in energy generation can be extremely efficient, the process itself – from iron-ore mining, through melting and forming wires and rods to the actual welding application – is very energy intense.

Especially in the age of the energy transition – the rethinking from fossil fuels to renewable energy sources – and the more conscious use of energy it is all the more important for both companies, the one manufacturing the welding materials and the one actually doing the welding, to act sustainably and energy-efficiently.

voestalpine AG takes its responsibility in this area very seriously – it has been regarded as the environmental and efficiency benchmark for the industry for decades. The group has invested hugely in environmental and climate protection over the past decade – around EUR 2.3 billion – as well as initiating research into alternative manufacturing processes, optimization of technologies and production facilities.

Apart from that, the company's individual business areas are happy to always be one step ahead – and concentrate their efforts not only on process optimization, but also on the development of new product technologies that contribute to sustainability.

“ Our R&D department came up with the perfect response to the growing demand for energy efficiency: the greenWave® technology.”

*Otto Schuster, Senior Vice President SBU Equipment*



# greenWave®

The responsible choice in welding.

greenWave® is a patented technology complying to the EN61000-3-12 standard and enabling an extremely energy-efficient operation with optimized power consumption.

greenWave® design combines all the benefits and reliability of inverter technology with a power factor equal to or approaching unity.

greenWave® provides a real opportunity for major improvement in technologically advanced companies and with end users who are ecologically aware and intent on respecting the environment.

Therefore Böhler Welding machines of the URANOS line are equipped with the energy saving greenWave® technology. They are easily recognizable from an adhesive label bearing the greenWave® logo on the cover.

# HOW WELDING MACHINES DEVELOPED – THE ORIGINS OF INVERTER TECHNOLOGY

## “First, there were electro-mechanical power sources”

Before the arrival of inverter circuits, arc welding current was generated by electro-mechanical power sources. These use transformers to convert high voltage, low current mains electricity into the low voltage, high current energy needed to strike an arc. In most cases, the welding arc is generated from a DC current, so power circuits have to include a bridge rectifier.

The simplicity and reliability of this technology have been much appreciated over the years.

Nevertheless, electro-mechanical systems present a number of disadvantages from the point of view of efficiency, portability and arc control.

For a start, because of the low frequency (50 Hz) of the mains supply, transformer based power sources need particularly large and heavy transformers. Greater size and weight have an impact on the environment and result in higher disposal costs at the end of the machine life.

Efficiency is another important factor. Large transformers suffer from higher losses in the core and the copper windings as the result of internal parts and the surrounding air becoming hot. Even a good electro-mechanic (step) power source will achieve an efficiency of no more than 75%.

On top of this, effective arc control is also difficult and costly in this type of power source. It is difficult and sometimes impossible to generate pulsed welding current, or to create current profiles that suit the different phases of the welding process (e.g. striking) and other specific requirements. In other words, serious technical barriers make it impossible to provide the advanced welding functions that a professional welder needs to adapt his technique to different situations and applications.

Typical electro-mechanical power source transformer  
weight: 59 kg  
dimensions:  
310 x 370 x 160 mm



Typical 400 A STEP welding power source  
weight: 107 kg  
dimensions:  
500 x 980 x 760 mm



URANOS NX 4000 PME inverter power source  
weight: 35,2 kg  
dimensions:  
290 x 690 x 510 mm



## “Then came the inverter technology”

An inverter is basically an electronic device that opens and closes a circuit at an extremely high frequency. Inverter circuits are able to feed transformers at a far higher frequency than that of the mains supply.

One of the key characteristics of the transformer is that its effective output voltage is proportional to mains supply frequency, to the number of spires in the transformer core, and to the core's dimensions. It is therefore obvious that if the mains frequency can be increased, the windings and the dimensions of the transformer core can be reduced while maintaining the same output.

Inverter circuits allow us to increase mains frequency from 50 Hz to an average working frequency of 50 kHz – one thousand times greater.

### Benefits of the inverter welding technology

- » Dramatic reduction in size and weight (≈-75%)
- » Reduction in electrical energy costs (≈-10/20 %)
- » Extremely effective and flexible arc control
- » New welding functions (pulsed MIG/MAG, robotics, AC/DC TIG etc...)

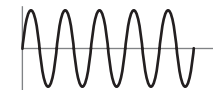
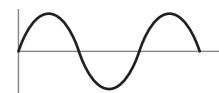

## “Final step, the use of inverter technology in a welding power source”

Mains voltage is first rectified then fed into an inverter circuit. In the inverter, the DC current is chopped up at a very high frequency determined by the characteristics of the inverter. The resulting high frequency alternating current is fed into a transformer which produces the voltage and current values required for welding, and is again rectified. This method of welding current generation delivers a number of benefits.

Because it only needs small transformers, power sources can be far more compact and far lighter, with obvious advantages in terms of portability. Small transformers also have lower transformation losses, and therefore deliver higher overall efficiencies. Depending on operat-

ing conditions, an improvement in efficiency of between 10 and 20% can be achieved.

Modern welding control systems have allowed arc welding technology to be adapted to new processes including pulsed MIG/MAG and double pulsed MIG/MAG, and

have delivered innumerable benefits for a wide range of applications. Inverter control has provided the functions and power levels needed to transform AC/DC TIG welding in particular from a specialist application into a popular industrial welding process.

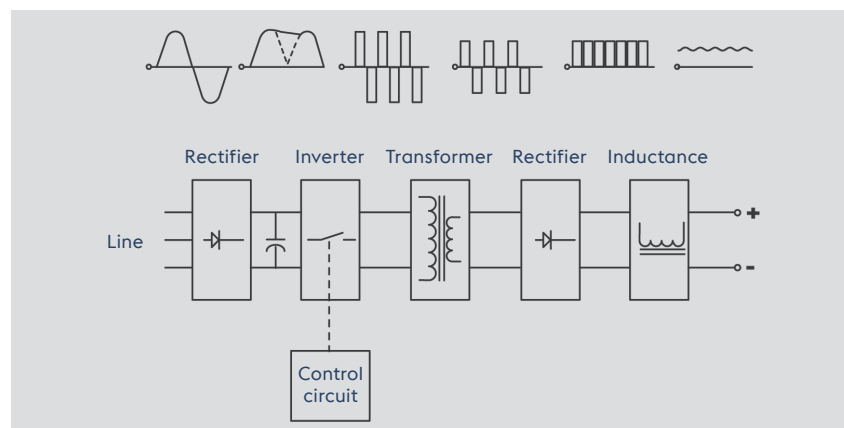

# POWER FACTOR – THE BENCHMARK FOR EFFICIENCY IN WELDING POWER SOURCES

“**In alternating current systems, depending on the type of electrical load, voltage and current may not alternate in phase: instead, there may be a shift between the two wave forms. When such a shift occurs, the power draw from the mains can be divided into the following parts:**”

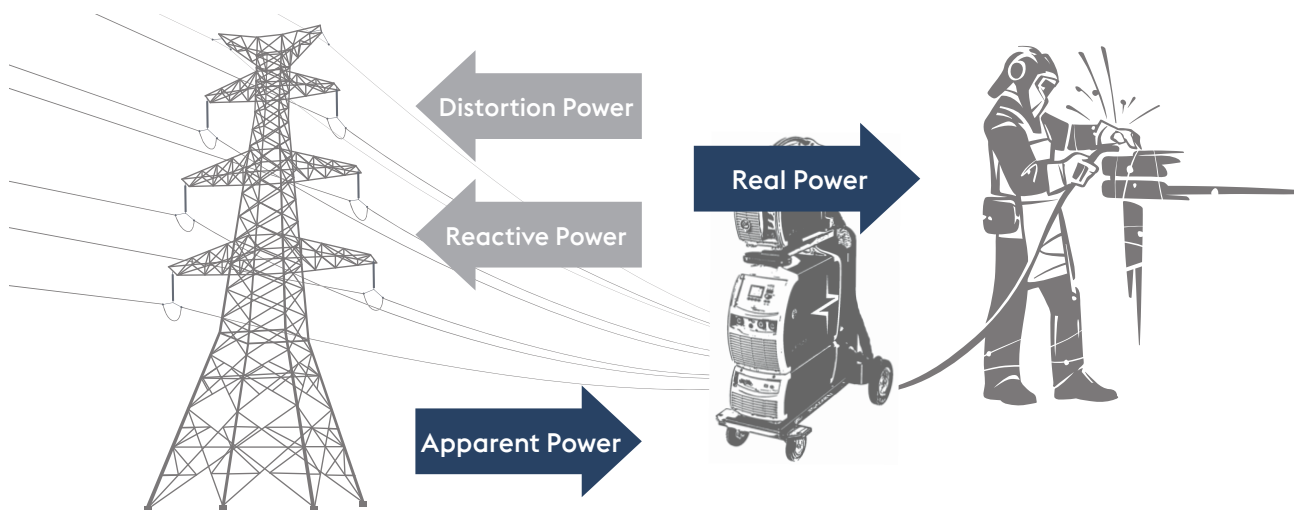

## Distortion Power

The type of reactive power generated by nonsinusoidal currents, expressed in kVA.

The power factor of a system that draws energy from an AC supply is defined as the ratio between its real power and its apparent power.

## Reactive Power

Power that the load draws but returns to the line (is not consumed by the welding power source), expressed in kVA.

## Real Power

Power actually consumed by the load (welding power source), expressed in kW.

## Apparent Power

The total amount of power drawn from the supply, inclusive of transmission losses. If the reactive component is caused only by the phenomenon of phase shift, the ratio between real power and apparent power can be defined as “ $\cos\phi$ ”. Unfortunately, reactive power is not caused only by the phase shift between voltage and current waveform. It is also caused by the presence of nonsinusoidal currents (i.e. currents that do not

have a perfect sine-wave form). Current flows to charge the capacitor only when AC input voltage exceeds the voltage of the capacitor. This current does not therefore have the classic full sine wave form, but is pulsed instead.

In this case, in addition to whatever reactive power is caused by phase shift, extra reactive power is caused by the distortion of the output waveform by these current pulses. This is: Distortion Power

“ Power factor therefore provides a measurement of the system’s efficiency in exploiting the energy delivered by the AC mains supply. A system with unity power factor (PF = 1) is able to exploit all the energy delivered by the mains supply, while a system with a PF of 0.65 can only exploit 65% of it.”

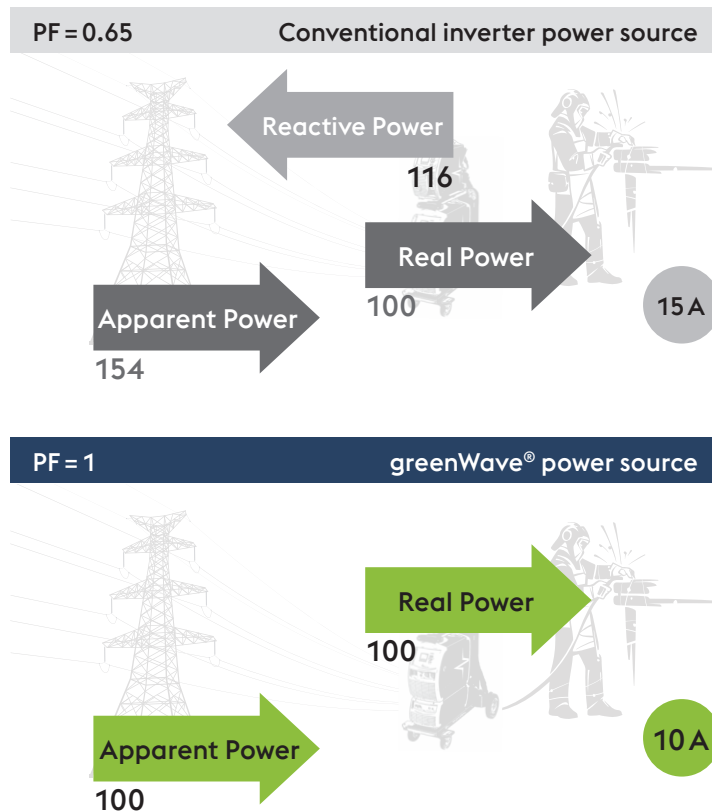

#### Example

- » 2 welding power sources performing exactly the same work
- » one has a PF = 1 and
- » the other has a PF = 0.65

$$PF = \frac{\text{Real Power}}{\text{Apparent Power}}$$

If the power source with PF = 1 needs to draw 10 A from the mains supply,

the other power source with PF = 0.65 will need to draw 15 A in order to generate an arc of exactly the same power.

It is important to understand that there is a fundamental difference between the concept of “cosφ” and that of power factor, since the two are frequently confused in welding sector technical documentation. “cosφ” measures a system’s efficiency bearing in mind only the component of reactive power caused by phase shift between the voltage and current waveforms.

Power factor (PF) is the only parameter that takes into consideration all the components of reactive power (phase shift and harmonic).

In certain places, mains voltage is far from stable and can fluctuate or vary. Conditions such as these can easily occur in areas where the distribution grid is

under-dimensioned, power lines are very long, or power is supplied by generator sets. To prevent such fluctuations causing faults or failures, the latest welding power sources incorporate input filter capacitors to compensate and stabilise the incoming mains supply. It protects the circuitry against component failures and, by ensuring stable operating conditions, also increases the average working life of internal components, thus further improving the reliability and precision of inverter-based welding power sources. Another benefit of stabilised input voltage is that the welding arc is also more stable, easier to control, and better able to perform the various functions and processes that have been developed following the introduction of inverter technology.

“ Despite these undisputable benefits, the use of input filter unfortunately penalises power factor.”

greenWave®

## THE SUSTAINABLE GENERATION OF POWER SOURCES

“Our research centre has developed an innovative design that combines all the benefits and reliability of inverter technology with a power factor equal to or approaching unity.”

Otto Schuster, Senior Vice President SBU Equipment

Patented greenWave® Multiline three level technology has led to the development of truly innovative power sources.

- » greenWave® technology combines all the performance of inverter power sources with protection against unstable power supplies and a power factor approaching unity.
- » greenWave® technology can function with single phase mains power supplies, in which case it ensures a power factor of unity, and with three phase mains supplies, in which case power factor closely approaches unity.

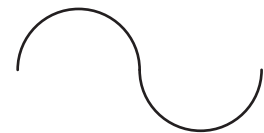

Single phase, PF = 1

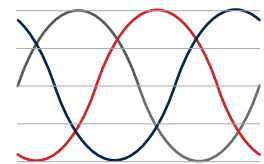

Three phase, PF ≈ 0.95

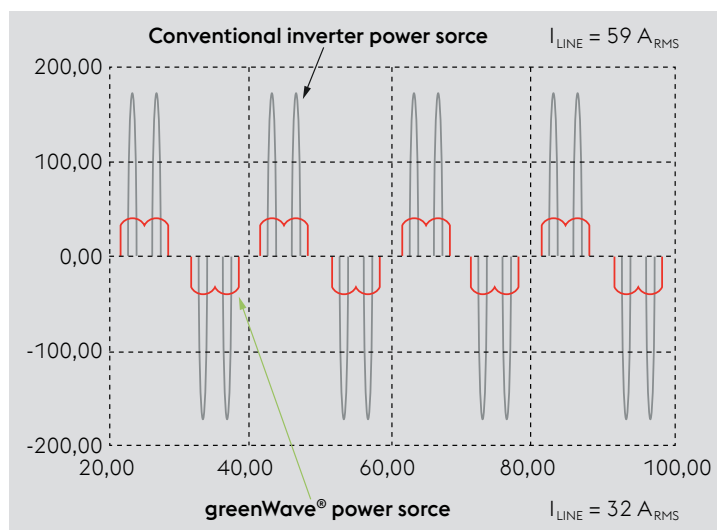

The diagram compares how a conventional inverter power source and a greenWave® power source draw three phase current.

In the first case, current is pulsed, leading to a high level of harmonic distortion and a large reactive component.

The result is a low power factor of  $PF \approx 0.65$ . In the greenWave® power source, current is almost sinusoidal, with the result that power factor approaches unity:  $PF \approx 0.95$ .



## “Why should you buy greenWave® technology?”

### 1. Complete protection against unstable mains supplies

greenWave® guarantees complete protection for internal electronic circuits and keeps the welding process independent of electrical supply conditions. This is particularly important when welding operations have to rely on under-dimensioned, fluctuating mains supplies or on-site gensets.

### 3. Better overall reliability

A unity power factor means a far lower current draw. This in turn means less stress on circuits and components, with doubtless benefits in terms of power source durability and reliability.

### 5. More power sources can be installed

greenWave® technology lets you either dimension your mains supply for a lower current draw, or increase the number of machines you can use for the same installed power.

### 2. Self-adaptation to input voltage (autolink)

greenWave® welding power sources adapt automatically to three phase mains supply voltage without any manual intervention.

### 4. Reduced system costs

greenWave® improves the overall availability of the electrical supply. The use of welding equipment that draws less current helps avoid exceeding maximum permitted load, thus avoiding costly shutdowns that eat into company profits.

Conventional inverter  
power source = 59 A  
(PF = 0.65)



greenWave®  
power source = 32 A  
(PF = 1)



Example: 64 A industrial mains supply 400 A pulsed MIG/MAG welding process

## 6. Conformity to the strictest standards

Because of the pulsed currents, conventional inverter power sources cause harmonic disturbance. This is transmitted back to the mains and increases current draw. With the introduction of standard EN 61000-3-12, limitations have been placed. The limits imposed by EN 61000-3-12 only apply to systems fed from the low tension, public grid. In the case of equipment powered from the public grid, installers and users are

required to ensure that the equipment conforms to EN 61000-3-12 standard. If it does not, users have to consult the electric company to ascertain whether or not the equipment can be connected to the mains. greenWave® welding power sources are already conform to EN 61000-3-12, and do therefore not require any further verifications to be made.\*

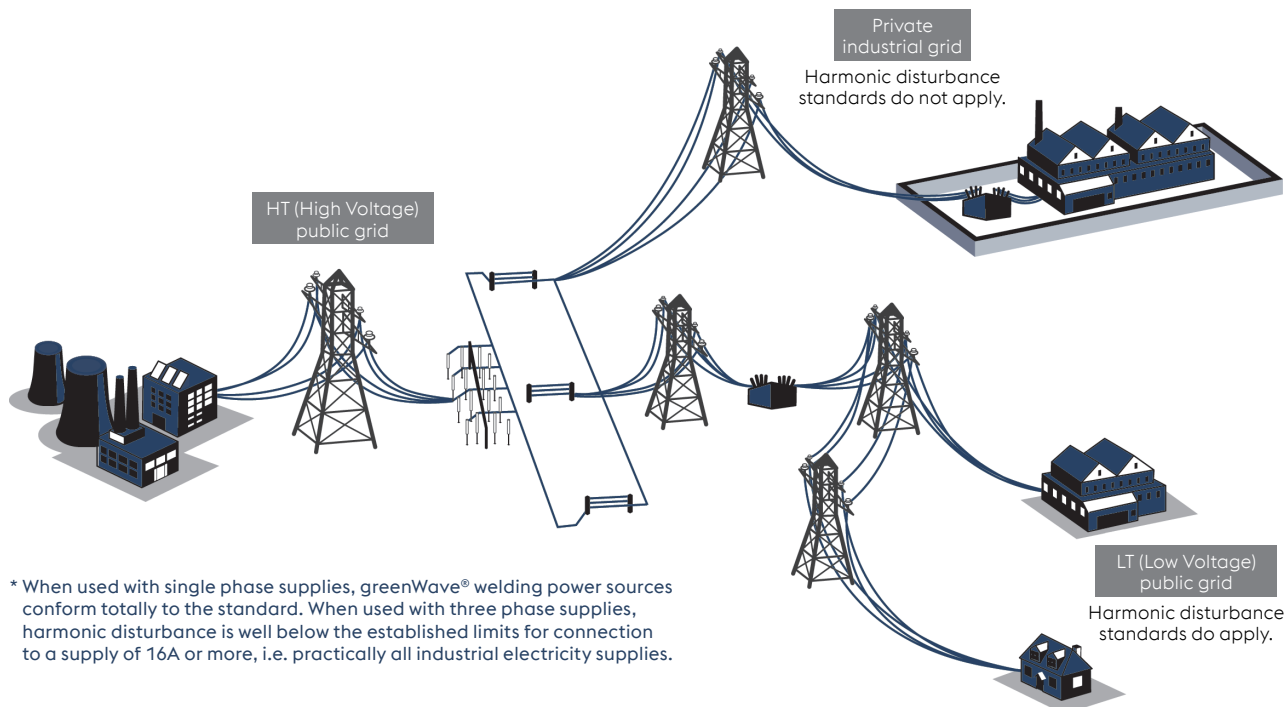

\* When used with single phase supplies, greenWave® welding power sources conform totally to the standard. When used with three phase supplies, harmonic disturbance is well below the established limits for connection to a supply of 16A or more, i.e. practically all industrial electricity supplies.

## 7. Reduction of between 70% and 100% in reactive energy consumption

More and more countries are implementing policies to minimize reactive energy. Many have already introduced billing systems that penalize the generation of reactive energy, and more are likely to follow soon. greenWave® welding power sources completely eliminate reactive power consumption with single phase power supplies, and dramatically reduce it with

three phase supplies. The more greenWave® power sources are operating along the production line, the bigger this contribution is. In addition, in factories and on sites where welding equipment is the principal cause of reactive power, the introduction of greenWave® power sources virtually eliminates the need to install costly and bulky phase correction systems.

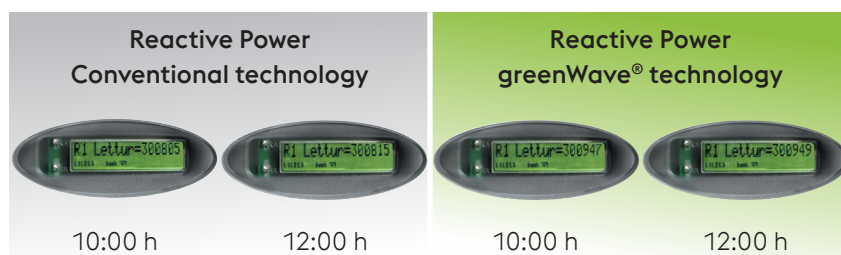

2h use of power source in industrial company

## 8. Over 50% reduction in joule effect losses

Thanks to the reduction in current draw, Joule effect losses are also reduced along power lines. A conductor through which electrical current flows dissipates energy in the form of heat as a function of current intensity. Losses in power lines downstream from the supply meter are at the expense of the user.

The use of greenWave® technology under the same operating conditions would reduce energy losses by half. The more welding machines are in action, and the longer the internal power distribution system, the higher the energy savings will be when using greenWave® technology.

3 MIG/MAG welding units 200 A		
Conventional inverter power source		greenWave® power source
▼		▼
15 A	CURRENT DRAW	10 A
▼	distribution over a 6 mm cable of 200 m length (considering resistivity of copper)	▼
1150 W	ENERGY LOSS	510 W
▼	operating 5h/day & 230 days/year	▼
1380 kWh	TOTAL ANNUAL LOSS	612 kWh
▼		
<b>ANNUAL SAVINGS: 768 kWh</b>		

## 9. greenWave® helps reduce CO<sub>2</sub> emissions

Power lines, because of the intrinsic resistance of their conductors, are subject to energy losses through heat dissipation. Because greenWave® power sources draw less current, they make a major contribution to reducing energy losses along power lines.

This in turn means lower emissions. Choosing an ecological greenWave® power source is therefore a way of taking collective responsibility for the environment.

**“1000 greenWave® power sources operating at 200 A / 28 V for 1200 hours a year correspond to a reduction in CO<sub>2</sub> emissions of about 110 tons.”**



# URANOS

## MIG/MAG STANDARD

### Designed for amazing welding performance

- » Particularly efficient MIG/MAG standard process for extremely precise welds
- » Enables very homogeneous and clean metallurgical properties
- » Very stable and perfectly controllable electric arc
- » High welding speed and melting capacity



### URANOS 200 SMC

200 A @ 35%  
1x230 V  
5 – 200 A  
12,8 kg



## MIG/MAG PULSE

### Perfect welding results thanks to "Digital Drop"

- » Enables optimum MIG/MAG pulse welding with consistent and reproducible performance thanks to new welding technology
- » Extremely stable and concentrated arc
- » Simple parameter control for efficient work



### URANOS MX2200 PMC

220 A @ 35%  
1x230 V  
3 – 220 A  
22,4 kg



## MULTIPROCESS

### Up to any welding task

- » Ideal for MMA, MIG/MAG pulse and TIG DC welding process
- » Designed to handle a wide range of welding tasks
- » Developed to meet the highest demands with regard to flexibility and performance
- » Perfect for repair and maintenance as well as training facilities



### URANOS MX2200 MTE

220 A @ 35%  
1x230 V  
3 – 220 A  
23,7 kg



## TIG DC

### The precision arc

- » Highly concentrated and stable electric arc
- » Aesthetically perfect welding seams
- » Optimum welding conditions in all working situations



### URANOS 1800 TLH

180 A @ 35%  
1x115-230 V  
3 – 180 A  
9,4 kg



## TIG AC/DC

### Best in class

- » Guaranteed concentrated and stable arc
- » Reduced heat input
- » High-quality weld seam and considerable increase in productivity with only one set value



### URANOS MX1700 AC/DC / 2200 AC/DC

170 / 220 A @ 35%  
1x115 - 230 V  
3 – 170 / 220 A  
18,8 kg



## “FOR THE HIGHEST DEMANDS Efficiency & technological excellence”

### URANOS **MX** 2200 SMC

220 A @ 35%  
1x230 V  
3 – 220 A  
22,4 kg



### URANOS **MX** 2700 SMC

270 A @ 45%  
3x230 - 400 V  
3 – 270 A  
23,0 kg

### URANOS **MX** 2700 PMC

270 A @ 45%  
3x230 - 400 V  
3 – 270 A  
23,0 kg



### URANOS **MX** 3200 PME

320 A @ 50%  
3x230 - 400 V  
3 – 320 A  
27,6 kg



### URANOS **MX** 4000 PME / 5000 PME

400 A @ 60% / 500 A @ 50%  
3x230 - 400 V  
3 – 400 A / 3 – 500 A  
36,2 kg / 38,5 kg

### URANOS **MX** 2700 MTE

270 A @ 45%  
3x230 - 400 V  
3 – 270 A  
23,5 kg



### URANOS **MX** 3200 GSM

320 A @ 50%  
3x230 - 400 V  
3 – 320 A  
27,6 kg



### URANOS **MX** 4000 GSM / 5000 GSM

400 A @ 60% / 500 A @ 50%  
3x230 - 400 V  
3 – 400 A / 3 – 500 A  
37,5 kg / 39,5 kg

### URANOS **MX** 2200 TLH

220 A @ 35%  
1x115-230 V  
3 – 220 A  
16,0 kg



### URANOS **MX** 2700 TLH / 3200 TLH

270 A @ 35% / 320 A @ 40%  
3x230 - 400 V  
3 – 270 / 320 A  
18,8 / 26,0 Kg



### URANOS **MX** 4000 TLH / 5000 TLH

400 A @ 60% / 500 A @ 50%  
3x230 - 400 V  
3 – 400 / 500 A  
35,4 / 37,3 Kg

### URANOS **MX** 2700 AC/DC

270 A @ 40%  
3x230 - 400V  
3 – 270 A  
27,0 kg



### URANOS **MX** 3200 AC/DC

320 A @ 40%  
3x230 - 400 V  
3 – 320 A  
27,5 kg



### URANOS **MX** 4000 AC/DC / 5000 AC/DC

400 A @ 40% / 500 A @ 45%  
3x230 - 400 V  
3 – 400 A / 3 – 500 A  
35,4 kg / 37,3 Kg



**Because Böhler Welding Cares**



Explore more sustainable products by Böhler Welding,  
e.g. ECOspark on our webpage  
<https://www.voestalpine.com/welding/>

# JOIN! voestalpine Böhler Welding

We are a leader in the welding industry with over 100 years of experience, more than 50 subsidiaries and more than 4,000 distribution partners around the world. Our extensive product portfolio and welding expertise combined with our global presence guarantees we are close when you need us. Having a profound understanding of your needs enables us to solve your demanding challenges with Full Welding Solutions - perfectly synchronized and as unique as your company.



**Lasting Connections** – Perfect alignment of welding machines, consumables and technologies combined with our renowned application and process know-how provide the best solution for your requirements: A true and proven connection between people, products and technologies. The result is what we promise: Full Welding Solutions for Lasting Connections.



**Tailor-Made Protectivity™** – The combination of our high-quality products and application expertise enables you to not only repair and protect metal surfaces and components. Our team of engineers, experienced in your specific applications, offer you customized solutions resulting in increased productivity for your demanding challenge. The result is what we promise: Tailor-Made Protectivity™.



**In-Depth Know-How** – As a manufacturer of soldering and brazing consumables, we offer proven solutions based on 60 years of industrial experience, tested processes and methods, made in Germany. This in-depth know-how makes us the internationally preferred partner to solve your soldering and brazing challenge through innovative solutions. The result is what we promise: Innovation based on in-depth know-how.

The Management System of voestalpine Böhler Welding Group GmbH, Peter-Mueller-Strasse 14-14a, 40469 Duesseldorf, Germany has been approved by Lloyd's Register Quality Assurance to: ISO 9001:2015, ISO 14001:2015, OHSAS 18001:2007, applicable to: Development, Manufacturing and Supply of Welding and Brazing Consumables. More information: [www.voestalpine.com/welding](http://www.voestalpine.com/welding)



